

# GRAVITY FEED METAL DETECTOR

## METALTRAP SS / GX-GF

For detection of metal contamination in Powder and Granules



TECHNOFOUR ELECTRONICS PVT. LTD.

[www.teplindia.com](http://www.teplindia.com)

### FFS Machine

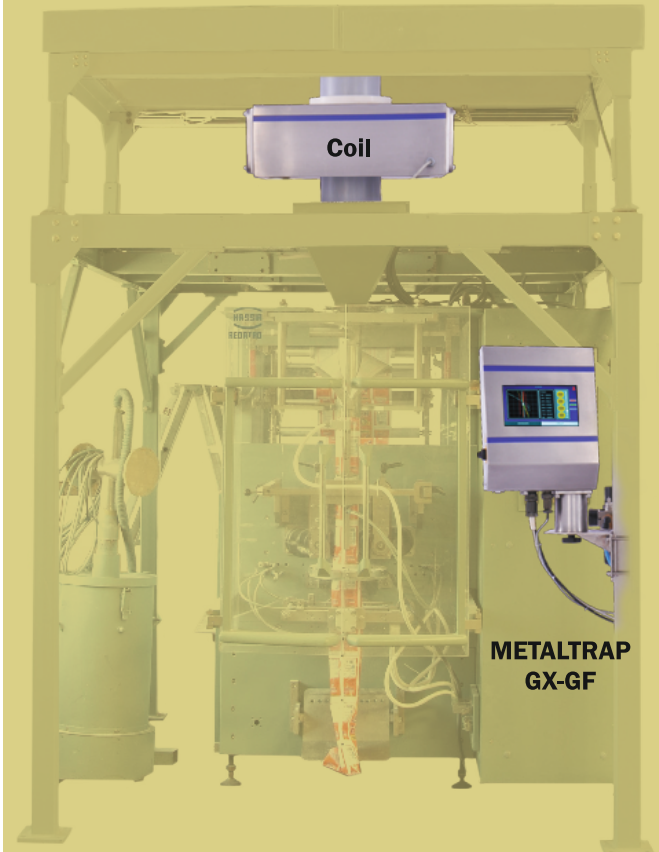

- Extremely Super Sensitive detection for all types of metals
- 4.5" HMI Display / 7" Touch Screen
- Auto Product Tracking
- Validation using prompt
- Rejection with Fail safe mechanism
- Statistical Data with event time stamping
- Digital Gains and Filters for enhanced sensitivity
- Phaser Display to analyze type of metal contamination

Gravity feed Metal Detector metaltrap SS/GX - GF is an eddy current based Digital Metal Detection system designed for Pharmaceutical, Chemical and Food Industries for detecting metal contamination in Powers and Granules.

### SALIENT FEATURES

- Auto setting facility
- Sample E - signature
- Product auto-tracking
- Validation using prompt
- Continuous online self check monitoring system
- Digital control and signal processing
- Set parameter data retention on loss of power
- Buzzer on detection of metal contamination
- Validation using prompt
- Digital Gains and Filters for enhanced sensitivity
- Flap type Rejection mechanism / floating relay contact
- Reject Time Stamping

### ADDITIONAL FEATURES

- 7" touch screen display
- Real X-Y Plot / Numerical + graphical display
- Live metal can be determined as ferrite or non-ferrite
- 5 years Batch data storage
- SCADA / IIoT connectivity
- Multilevel password
- Finger print sensor (optional)

### TEST COIL

- **Aperture size:** 2" to 8" dia.
- **Sensitivity:**  
Depends upon the aperture size and product

### Stand:

Provided depending on application  
Wheels for Transportation Movement

### Utility Requirement:

**Electrical:** 220V AC / 50 Hz / 200 VA

**Pneumatic:** 6 kg/cm<sup>2</sup>

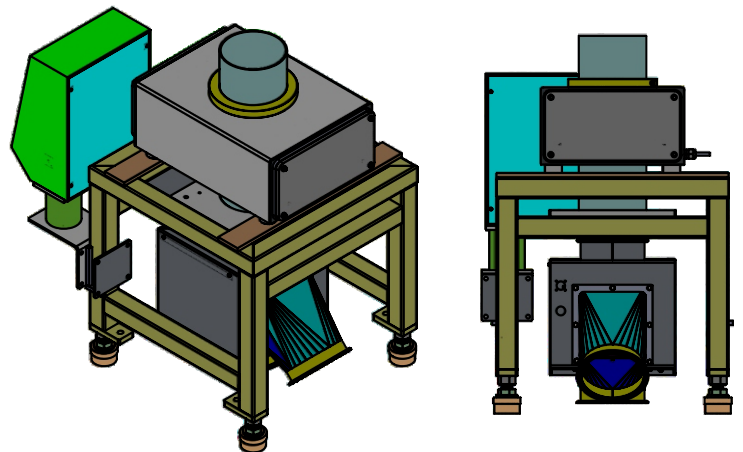
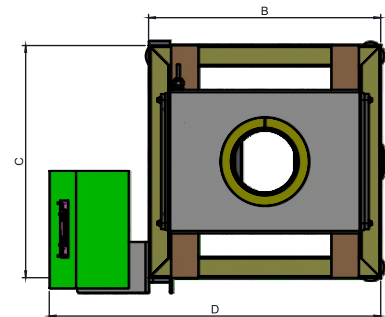
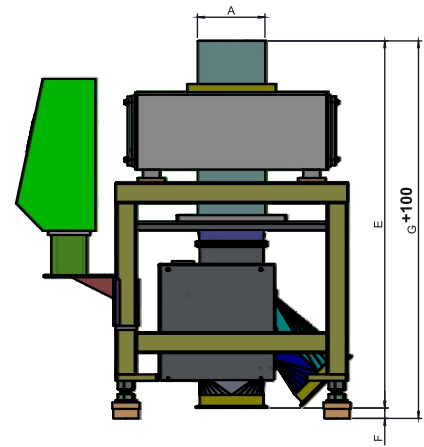

	A	B	C	D	E	F	G
GF50	63	485	550	720	870	24.5	900
GF100	110	485	485	720	870	24.5	900
GF150	160	550	550	790	870	24.5	900



**TECHNOFOUR ELECTRONICS PVT. LTD.**

Gat No.3(PT), 5(PT), 243(PT), Kasurdi (Kheba),  
Khed Shivapur-Saswad Road, Post: Khed Shivapur,  
Taluka: Bhor, District: Pune 412 205. Maharashtra, India.  
Tel: 8888832057, 8888832194, + 91-2113-305200, 305246  
Email: pcssales@tepl.co.in  
Website: www.teplindia.com

\* Due to continuous development, specifications subject to change without notice.